

Type 1 GPS Only

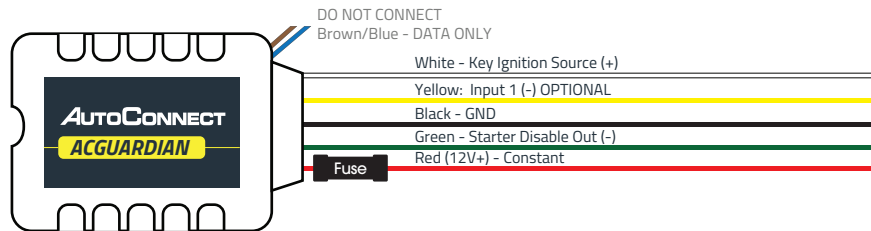

1. Connect Red wire to Constant +12V and fuse.
2. Connect Black wire to Ground.
3. Connect White wire to True Ignition (+).

Type 2 GPS with Starter Disable (optional)

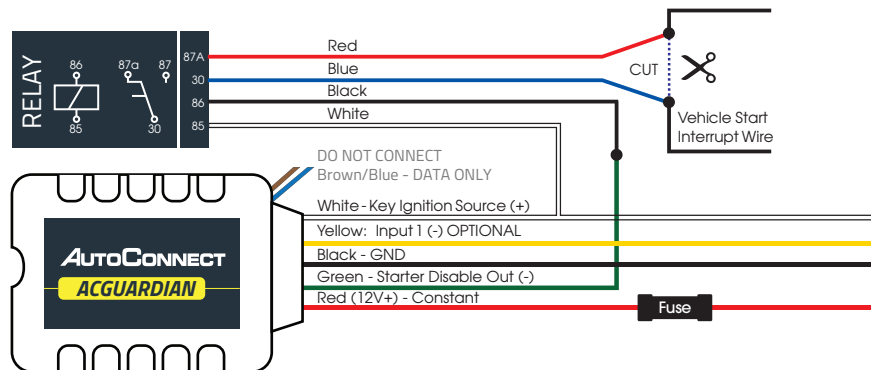

1. Connect Red wire to Constant +12V and fuse.
2. Connect Black wire to Ground.
3. Connect White wire to True Ignition (+).
4. Connect Green wire to relay.

QUICK INSTALL GUIDE

ACGUARDIAN



**12V
ONLY!**

CERTIFIED
TRACKING SOLUTIONS

MUST BE TESTED!

CALL TO TEST GPS TRACKING DEVICE BEFORE CLOSING UP THE DASH
FAILURE TO FOLLOW THESE INSTRUCTIONS MAY DAMAGE EQUIPMENT AND VOID ITS WARRANTY

1.855.287.4477

8AM - 5PM Monday to Friday MT

CERTIFIED TRACKING SOLUTIONS

IMPORTANT!

The device is delivered in "Shipment Mode." To take the device out of "Shipment Mode," you must perform either of the two following options:

- Complete the instructions below, including ignition connection, and turn the ignition "ON."
- Connect the white ignition (+) wire to a 12V constant power until lights on device come on (*Do not leave the white (+) ignition connected to constant power or it will drain the battery.*)

1 Select in-vehicle device location

This device is equipped with an IP65 dust and water resistant case making it suitable for a wide range of applications.

- Securely position the device with the correct side pointing skyward. (device label indicates proper orientation)
- Do not cover with metal or position near any source of interference.
- Failure to follow these instructions may result in weak cellular and/or GPS signal and will impact the performance of the device.

2 Connect ignition

In order to function properly the device needs to be connected to a suitable "True" Ignition source

- This source has battery voltage whenever the vehicle is turned on and zero volts whenever the vehicle is turned off.
- This source does NOT drop in voltage during crank.
- Connect the White wire to the ignition source.
- This source must operate the same when starting by key or by remote starter.
- If connecting starter disable, the ignition source must provide sufficient power to trigger the relay.

3 Connect constant power

The device requires a minimum 12V constant (Battery Power) on this line to function

- Do not remove/bypass the fuse.
- Connect the Red wire to a constant 12V source.

4 Connect ground

For best results, create a new connection to bare-metal chassis ground

- Do not use a shared ground or supplied ground from any module or device.
- Connect the Black wire to ground.

5 Connect starter disable (optional)

See Type 2 diagram for more information on installing the starter disable. Contact CTS tech support for additional assistance.

6 Testing IMPORTANT! Follow one of the test procedures below:

Call to test - Call CTS with ESN# to test the ignition, GPS, and starter kill (if applicable)
or

Self Test - Login to view and test the device using the instructions below:

a) Confirm vehicle connectivity and GPS location

- Click login on autoconnectgps.com and enter your username and password. Successful login will enable you to see the current location of the device on the website.

- Click on device serial # on the left side of the screen. The asset info box will open on the bottom left corner of the screen.

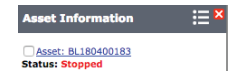

- Click on the "Asset Commands & Controls" icon located at the top of the Asset Info box.

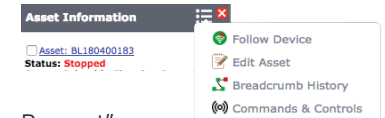

- Click on command labeled "A – Bulls Eye Position Request". A successful completion of this command will result in a checkmark being displayed and the current time will update in the "Last Comms" section of the asset info box.



- The vehicle icon on the map should now have a red "dot" below it. If it has an exclamation mark ("!"), it means that the device has "invalid" GPS. In this case you will need to move the vehicle outside and issue the Bulls Eye request again.



b) Starter disable test (If applicable)

Click on the "Activate Starter" after logging into autoconnectgps.com. Please see the Starter Kill wiring diagram for recommended wiring. If successful you will not be able to start the vehicle. Click on the "Deactivate Starter Kill" to allow the vehicle to start again.

c) Verify ignition status

Ensure the vehicle is no longer running. Once logged into the AutoConnect dashboard, click on the device serial # on the left side of the screen. The asset info box will open on the bottom left corner of the screen. Verify that the status of the ignition says "off".